

Item No.:

Qty.:

Project:

MF 250.2 2T Pass Thru ROLL IN Blast Chiller and Shock Freezer



MultiFresh®: the multi-function assistant that will organize your production and processes with flexibility 24 hours a day.

MultiFresh is the first and only machine in the world that can run operating cycles with temperatures from 185° F to -40° F preserving its consistency, moisture content, and nutritional properties.

Multifunction 7" touchscreen display, product specific cycles, wide range of options, customization of all the parameters for each cycle.

Capacity

Capacity: 2 x Combi Oven Trolley (sized for 18"x26" pans)

Capacity: 4 x SLIM Rack (sized for 12"x20" pans)

Yield

Blast chilling capacity (194F to +37°F) 551 Lbs. (within 90 min or less)

Shock freezing capacity (194F to 0°F) 551 Lbs. (within 240 min or less)

R452a gas: Blast Chilling and Shock Freezing.

R448a gas: Blast Chilling only.

Product Warranty Protection

- 2 years, parts and labor.
- 5 years, compressor.

Certification



Standard Construction Features

- CABINET + REMOTE CONDENSING UNIT.
- All type 304 stainless steel construction.
- CFC-free high-density polyurethane insulation.
- Full width door with low-temperature resistant magnetic gasket.
- MultiSensor® 5-point probe for perfect temperature control.
- Automatic switch from manual mode (timed) to automatic mode (with probe) when probe is not inserted.
- The approved R452A refrigerant, used in a sealed system, is suitable for both blast chilling and shock freezing. The approved R448A refrigerant, used in a sealed system, is suitable for blast chilling only.
- High efficiency evaporators with multiple injection points.
- Data port & Wi-Fi capable data transfer to HACCP software.
- Door hinged right.
- End-of-cycle hold mode.
- Self-contained, air-cooled energy efficient condensing unit.
- Manual defrosting required at the end of the day.
- SANIGEN sanitation system.
- 2-1/4" thick insulated floor.
- Sunken Floor.
- Drain on left side (different position on request).

Unique Design and Performance Features

- 4 cycles in standard mode, 43 product specific cycles in dynamic mode; ability to record up to 20 replicable cycles into customized recipe book.
- Indirect air distribution and special airflow pattern to ensure perfect temperature uniformity.
- Moisture preservation system by "delta-t" control.
- MultiFresh® touch screen.
- Smudge-resistant controller touch pad.
- Easily accessible evaporators and waterproof fans.
- 30-40% more energy efficient than average competitor models with faster chilling times, all while preserving freshness, fragrance and organic properties of the food.

Option and Accessories

- Door hinged left.
 - Ramp.
 - Sous-vide core probe.
 - 120° or 100° Door Stop.
 - Knocked down.
 - City line or Water Tower Remote Condensing unit.
 - Pass thru version.
 - Mirror Unit.
 - Additional core probe.
 - Magnetic Door Stop.
 - Freshcloud Connection Kit.
 - Winter Package.
 - Correctional Packages.
 - Anti-Vibration Feet for Condensing Unit.
 - Cabinet Lighting.
 - 14" or 24" Ramp Options.
- Available PLUS model version with heat cycles: THAWING, HOLDING (hot or cold), REGENERATION, PASTEURIZATION, PROOFING, LOW TEMPERATURE COOKING.

CABINET

FRONT VIEW

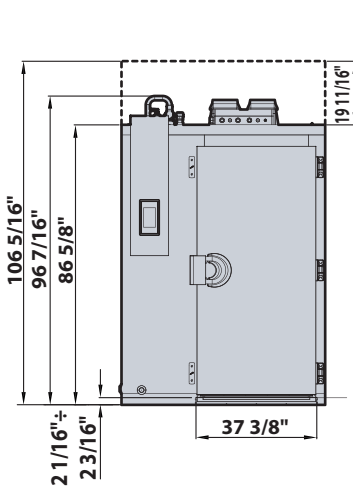

SIDE VIEW

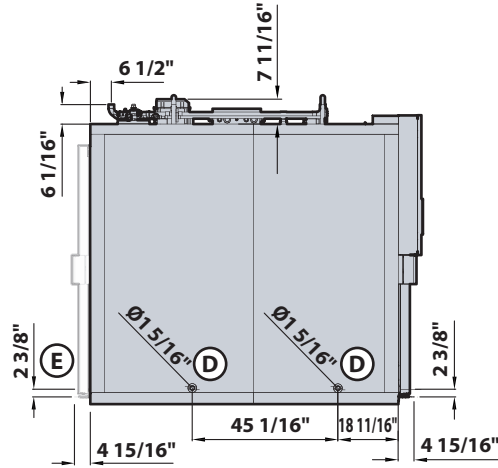

TOP VIEW

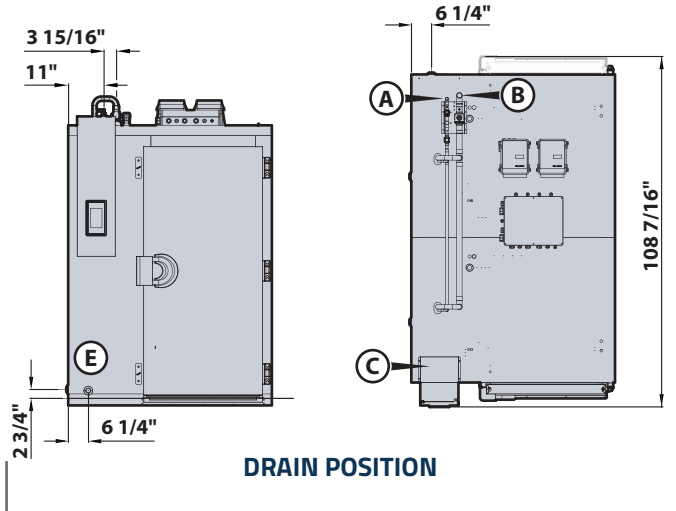
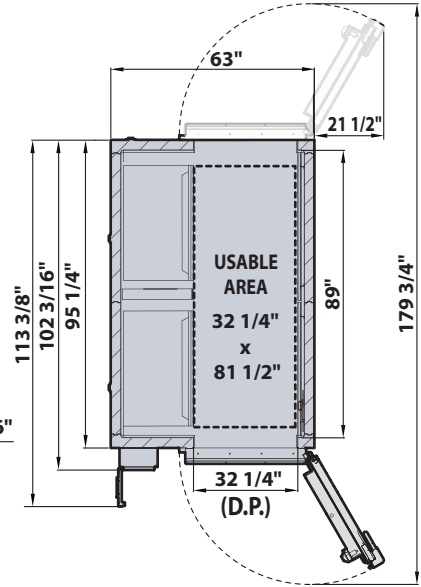

DRAIN POSITION

GENERAL CHARACTERISTICS

(A)	Liquid line connection		
(B)	Suction line connection		
(C)	Communication power cable inlet		
(D)	Standard drainage discharge	øIn (ømm)	1" 1/4 DN32
(E)	Drainage discharge on request	øIn (ømm)	1" 1/4 DN32

(D.P.) = Door passage

The back door is optional and on request

STANDARD PACKING

Gross Weight	Lb	2095
Dimensions (W x D x H)	In	114" 15/16 x 68" 7/8 x 100" 3/8 N°1
Volume	ft³	460.09

Item No.:

Qty.:

Project:

TECHNICAL DATA

Electric supply:		208V-3+PE 60Hz	
Variants		Standard	PLUS
Power rating	kW	6.7	22.2
Current rating	A	20.9	62.0
Minimum circuit amps (MCA)	A	21.0	73.0
Max overcurrent protection device (MOPD)	A	25.0	70.0
Main power cable	AWG	10AWG/4C	2AWG/4C
Section of electrical cable between cell and unit	AWG	14AWG/5C	
Refrigerant type:		R452a / R448a	
Maximum ambient air temperature:	°F	90	
Cabinet weight:	Lb	1764	
Effective internal Cell volume	ft ³	124	
Sunken floor (standard)		✓	
Maximum height of the cell with sunken floor	In	94" 5/16	
Pit Dimensions(Sunken Floor Version) W x D x H	In	63" 3/8 x 95" 11/16 x 2" 3/16	
Floor with ramp option		✓	
Maximum height of the cell with ramp	In	96" 7/16	
Standard ramp length	In	23" 5/8	
Optional ramp length	In	14"	
Ramp height	In	2" 5/16	
Ventilated floor with ramp option		✓	
Maximum height of the cell with ramp and ventilated floor	In	97" 1/4	
Ramp length	In	23" 5/8	
Ramp height	In	2" 5/16	

TUBES CONNECTING TO THE CONDENSING UNIT

Liquid Line Connection	øIn (ømm)	7/8" (22.22 mm)
Suction line connection	øIn (ømm)	1" 5/8 (41.27 mm)
Valid for condensing units installed up to a distance of	ft	95 *

*: If a lineset is longer than 95ft to please contact the manufacturer for any changes to line sizes and p-trap placement.

BLAST CHILLER SIZE

		R452a	R448a
Yield for blast chilling cycle: (194/+37°F)	Lb	551	551
Yield for shock freezing cycle: (194/-0°F)	Lb	551	-

R452a gas: Blast Chilling and Shock Freezing.

R448a gas: Blast Chilling only.

Specification could change without notice due to continuous product development.

UNIT

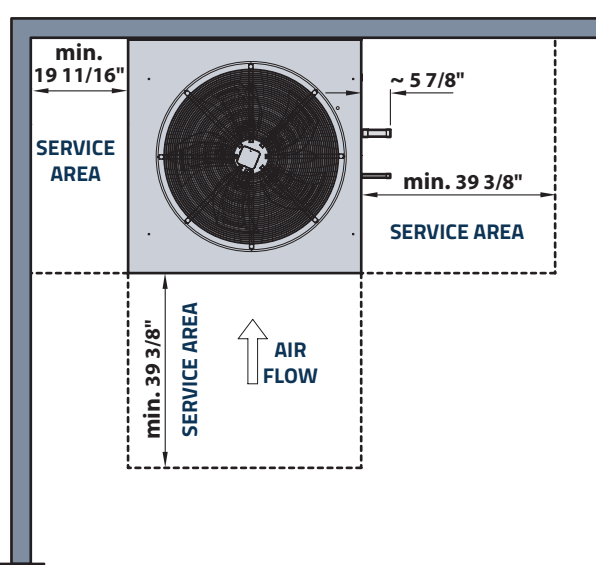
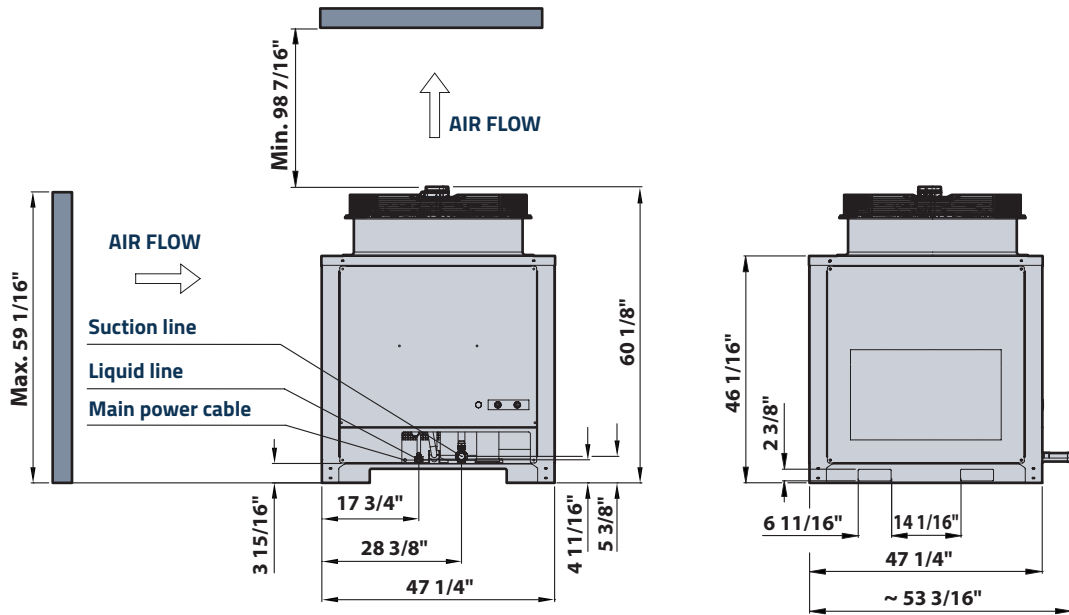

STANDARD PACKING

Gross Weight	Lb	816.00
Dimensions (W x D x H)	In	58" 1/4 x 58" 1/4 x 68" 15/16 x N° 1
Volume	ft³	137.00

Item No.:

Qty.:

Project:

TECHNICAL DATA

Electric supply:		208V-3+PE 60Hz
Power rating	kW	21.5
Current rating	A	69.5
Minimum circuit amps (MCA)	A	85.0
Max overcurrent protection device (MOPD)	A	125.0
Main power cable	AWG	4AWG/4C
Cabinet / condensing unit connection cable	AWG	14AWG/5C
Compressor rating	HP	15
Max cabinet refrigeration power at 14/104 °F (R452a/R448a)	btu/h	108454 / 101645
Max condenser heat dissipation at 14/104 °F (R452a/R448a)	btu/h	148663 / 137725
Refrigerant type:	-	R452a / R448a
Refrigerant PRE-load	oz. gas	493.8
Liquid Line Connection	øIn (ømm)	7/8" (22.22 mm)
Suction line connection	øIn (ømm)	1" 5/8 (41.27 mm)
Compressor displaced volume	ft ³ /h	2066.7
Total air flow	ft ³ /h	677952
Maximum ambient air temperature:	°F	108
Remote unit weight:	Lb	679
Oil Charge	gal	0.75

Continued product development may necessitate specification changes without notice.

Irinex North America

9990 NW 14th Street Suite 107 Miami FL 33172

Phone. (786) 870 5064 Fax. (786) 391 2467

www.irinoxprofessional.com/usa/ | info@irinoxnorthamerica.com