

Item No.:

Qty.:

Project:

## EASYFRESH® NEXT SL



The all new EasyFresh® Next R290 Blast Chiller - Shock Freezer offers the NEXT level of accelerated refrigeration performance, reliability, panel navigation, customization, and environmental consciousness, combined with affordability and enhanced options to expand the units capabilities and recognize a faster ROI.

In collaboration between engineering and culinary the EasyFresh® Next offers two configurations. Essential and Excellence.

Essential, include Blast Chilling, Shock Freezing, Non-Stop, Cold and Freezer Holding and Defrosting.

Excellence, include all the capabilities of the Essential as well as addition functions like Thawing. The Excellence series expands the cabinet temperature range and has a total of 8 different functions with 14 chef designed and engineer tested cycles. Easy to use, it allows the parameters of each cycle - temperatures, times and ventilation - to be changed in a few simple steps and saved to a favorite's menu for future use.

In both configurations Irinox preserves product freshness, reduces chill and freeze times, naturally extends product shelf life, maximizes labor efficiencies, increasing product yields, while enhancing the customers dining experience.

EasyFresh® NEXT provides the solutions to your HACCP needs with recorded cycle tracking and easy transfer to a USB or to the FreshCloud® Blast Chilling needs.

### Yield

Blast chilling (194°F/37°F) within 90 min 45 lb

Shock freezing (197°F/0°F) within 240 min 45 lb

\*Tests carried out in compliance with the Irinox procedure using 2" thick beef.

### Capacity

Number of trays: 5 18"x26" sheet pans

8 12"x20"x 2 1/2 steam table pans

### Standard construction details

- Self-contained, air-cooled, energy efficient condensing unit, with R290 refrigerant gas in sealed system.
- Indirect air distribution and special airflow pattern to ensure perfect temperature uniformity.
- 4.3" capacitive touch screen.
- Door hinged Left.
- 6" stainless steel adjustable feet.
- Irinox Patented interior door liner to magnetically store core temperature probe.
- Two (2) stainless steel wire shelves 26 5/8" x 18 1/4".
- Removable stainless steel pan supports, adjustable spacing.
- 1-point probe for perfect temperature control.
- Data port & Wi-Fi capable data transfer to HACCP software.

### Certification



Item No.:

Qty.:

Project:

## Operation

### 2 available configurations:

**Essential.** This is the basic configuration that includes the most popular blast chiller functions: chilling, freezing, non-stop, cold holding and defrosting. Regardless of the temperature at which the product is introduced, it always guarantees excellent results in terms of quality and temperature uniformity inside the cell.

**Excellence.** The multi-function configuration including 8 functions. In addition to the cold functions, in the Essential configuration you will find: thawing, ice cream retrieval.

- EasyFresh® Next's chilling cycles lower to 37°F the core temperature of the food, introduced at any temperature, even as soon as it is out of the oven, and quickly cross the band of maximum bacterial proliferation, the cause of its natural ageing.
- The EasyFresh® Next's freezing cycles transform the water contained in food into microcrystals that preserve its structure and quality for longer.
- At the start of the cycle, the operator can choose whether to use the core probe (automatic mode) or to work in time mode (manual mode).
- The non-stop cycles continuously chill or freeze to the desired temperature quantities of food that are prepared and placed in the blast chiller in succession. Set a notification when the chosen temperature or cycle time is reached.
- The cold holding cycles allow the blast chiller to be transformed into an additional space for storage at the desired temperature for short periods of time.
- The thawing cycle allows to choose the temperature and time at which your food is defrosted and ready for use, slowing down the bacterial growth process.
- The ice cream retrieval cycle allows to quickly bring the ice cream to display temperature in the shop window, ready for sale.
- The defrost cycle removes ice and excess condensation. It has an adjustable duration of 30 minutes and must be run at the end of the day or after intensive use with a high number of door openings.

### Performance

EasyFresh® Next guarantees a chilling and freezing capacity of 45 lb, thanks to the new propane refrigeration system.

In the Essential configuration, performance is ensured by a propane single circuit with dual reciprocating compressor, ventilated evaporator and a single-speed condenser fan.

In the Excellence configuration, the blast chiller uses a 5-speed "EC" electronic evaporator fan.

Thanks to its climate class 5 design, the blast chiller guarantees the stated performance up to an ambient temperature of 104 °F.

### Interface

**4.3" display** with capacitive colour screen. With acoustic signal with adjustable intensity and fixed tone.

The operator has the possibility of customizing and/or creating new cycles, which are stored in the library.

### Connectivity

FreshCloud® is Irinox's IOT technology that allows to control and interact with EasyFresh® Next at any time via an APP. The functions included in the application are:

- Remote monitoring of the cycle in progress: connection status, cell temperature, core temperature, kitchen and machine name, cycle ID in progress, cycle and phase progress.
- Remote parameter modification (ventilation, cabinet temperature, core probe temperature, phase duration, cycle management).
- Machine status monitoring: connection status, machine ID, laboratory name, serial number, door status, Sanigen® level.
- Usage statistics viewing.
- Haccp report download.
- Software update.

## Optional

- Additional pair of tray slides.
- Door hinged right.
- Locking castors (2 with brake and 2 without) H 3 6/7".
- Cabinet height H 35".
- Sous-vide core probe (optional replaceable to standard).
- Extra Wire Shelf 26 5/8" x 18 1/4".
- Stand EF Next SL + Rational new iCombi Pro 6-1/1E/G (with unit with castors or low profile legs only).
- Stand EF Next SL + Rational new iCombi Pro 6-2/1E/G (with unit with castors or low profile legs only).
- Additional core probe.
- Core probe holder for liquids.
- Low profile legs - height 3" 5/32- 4" 17/32.
- Sanigen® automatic sanitization system (eliminates 99.5% of all bacterial load inside product chamber).

## Product warranty

12 months from the date of receipt of the equipment; 24 months from the date of installation, subject to completion and submission of the installation report on FreshCloud®. For more details, see the sales conditions available at [www.irinoxprofessional.com](http://www.irinoxprofessional.com).

Item No.:

Qty.:

Project:

## EASYFRESH® NEXT SL

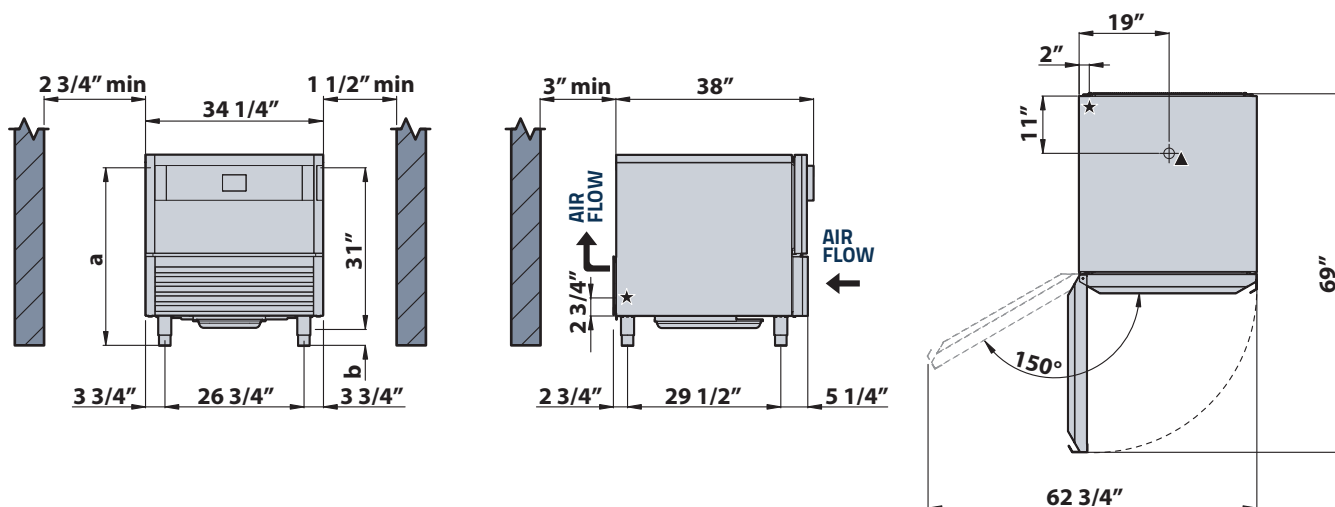

### HEIGHT

		HEIGHT (a)	FEET RANGE (b)
Standard feet	in	37" - 38" 7/8	6" ± 7" 7/8
Lowered feet option	in	-	- ± -
Castors option	in	35"	3" 6/7

★ Main power cable

▲ Water drainage (corrugated hose Ø32mm)

### TECHNICAL DATA

		208V - 1+PE 60Hz	
		ESSENTIAL	EXCELLENCE
Electric supply:		208V - 1+PE 60Hz	
Performance		ESSENTIAL	EXCELLENCE
Power rating	W	1001	1070
Total Amps	A	4.6	5.5
Minimum circuit amps (MCA)	A	6	8
Max overcurrent protection device (MOPD)	A	10	10
Rated load amps (RLA)	A	25.43	25.43
LOW TEMP COOKING power	W	-	831
LOW TEMP COOKING amps	A	-	4
Main power cable	AWG	3AWG14	
Refrigeration yield (14/+104°F; Tsuct +68°F; Subcooling 0°C)	btu/h	4263	
MAX Condenser rating (23/+113°F; Tsuct+68°F; Subcooling 0°C)	btu/h	6309	
MIN air flow for ventilation	ft³/h	38841	
Refrigerant type	oz	R290 - 5.29 oz	
Min/max installation ambient temperature	°F	59 / 104	
Max installation elevation	ft	6560	
Internal cell dimension (WIDTH x DEPTH x HEIGHT)	in	28" 3/4 x 22" x 14" 3/4	
Cabinet weight	Lb	309	

### INSTALLATION

The blast chiller must be installed following and complying with what is stated in the appropriate installation manual. The contents of the manual must be carefully followed to ensure correct operation and to protect the user's rights under the warranty.

Continuous product development may require changes to specifications without notice.

### Irinnox North America Inc.

9990 NW 14th Street, Suite 107 - Miami, FL 33172 USA

Tel.: 786.870.5064 | customersupport@irinnoxnorthamerica.com | www.irinnoxprofessional.com/usa/